

PRORIL

50Hz

GOBITS Series, these grinder pumps meet the demanding needs of commercial and residential sewage applications. GOBITS series pumps employ a grinding mechanism to effectively grind and transfer solids under high pressure from one place to a higher or a distant place. Ideal for residential and low-pressure sewer applications.

Sewage Pump

GOBITS 15/22

Grinder Pump



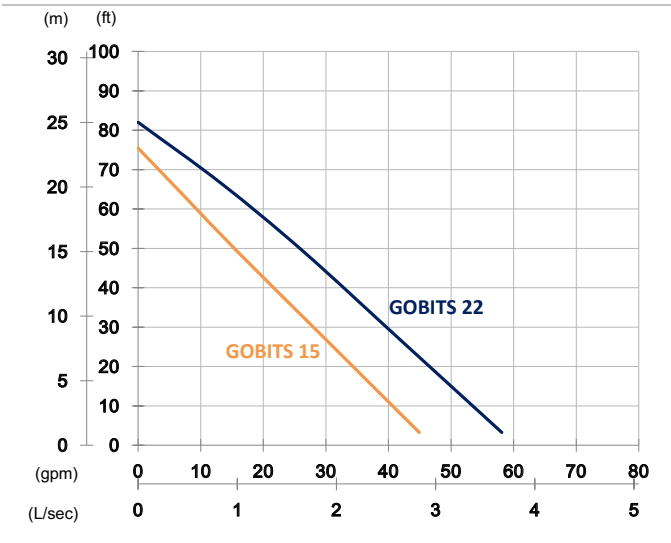

	GOBITS 15	GOBITS 22
OUTPUT	1.5 kW (2 HP)	2.2 kW (3 HP)
OUTLET	1.25" (32 mm)	2" (50 mm)
Weight	35 kg	35 kg
HEAD	Rated: 15 m Max: 23 m	Rated: 15 m Max: 25 m
FLOW	Rated: 1 L/s Max: 2.8 L/s	Rated: 1.7 L/s Max: 3.7 L/s

Pump Type	Electric Submersible Pumps		
Motor	Phase	1-Phase, 3-Phase	
	Type	Induction Motor	
	Poles	2 Pole (2850 rpm)	
	Insulation	Class F	
	Protector	Circle Thermal Protector	
	Starter	1-Phase · Capacitor-Start (15), 3-Phase · D.O.L.	
Lubricant	Food Grade (ISO VG32)		
Specs.	Impeller Type	Vortex	
	Shaft Seal	Double Mechanical Seal	
		Silicon Carbide VS Ceramic/Carbon	
	Bearings	C3 Shielded ball bearings	
	Cable	H07RN-F	
10 m or longer upon request			
Materials	Pump Casing	Gray Iron	
	Impeller	Gray Iron	
	Motor Frame	Gray Iron	
	Motor Shaft	Stainless Steel	
	Grinder Set	Chromium Iron	
Max. Liquid Temperature	40°C (104°F)		
Max. Submersion Depth	20 m (66 ft)		
pH Range	pH 5 - pH 8		
Guide Rail	GRL-02		

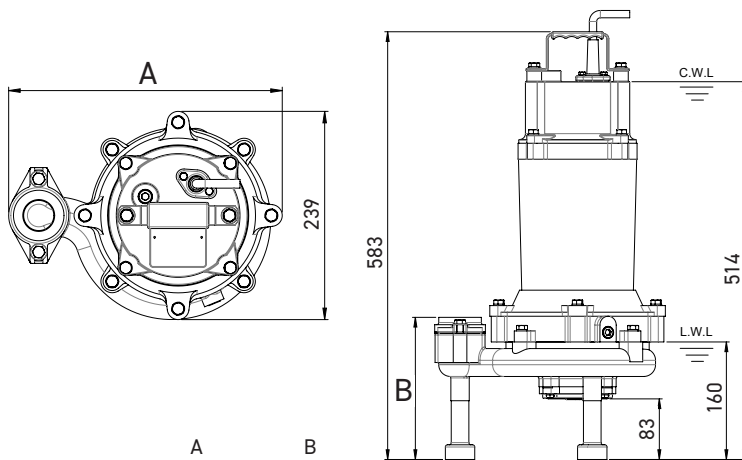

	A	B
GOBITS 15	314	194
GOBITS 22	316	198

unit : mm
C.W.L : Continuous running water level
L.W.L : Lowest running water level